

Mounting Base

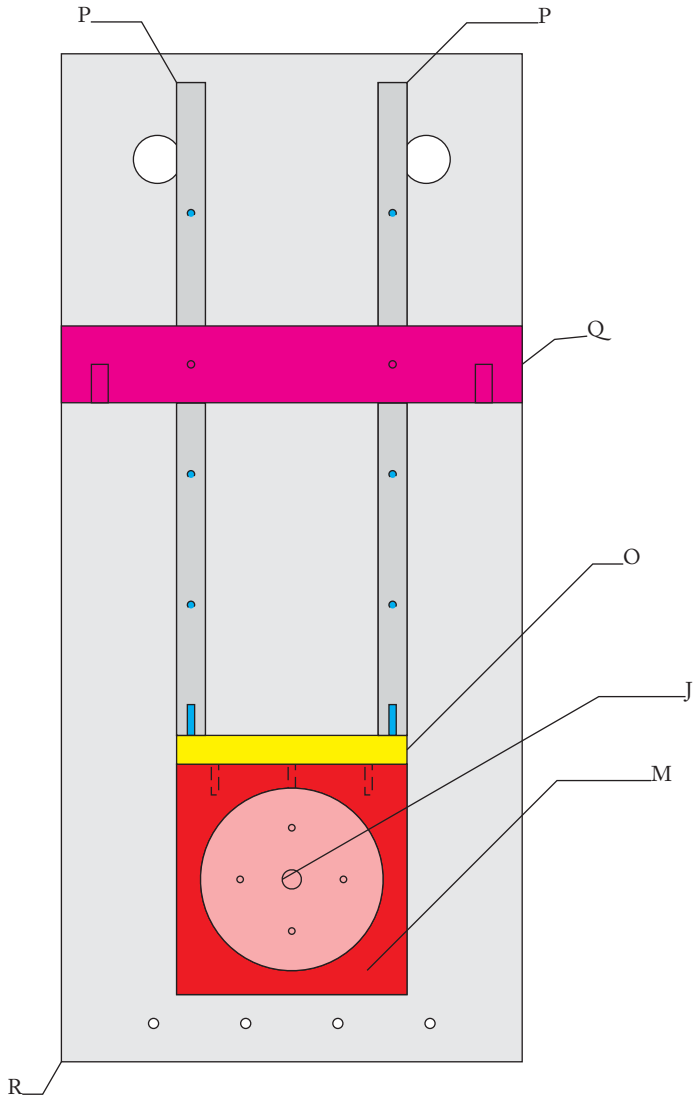

Top View

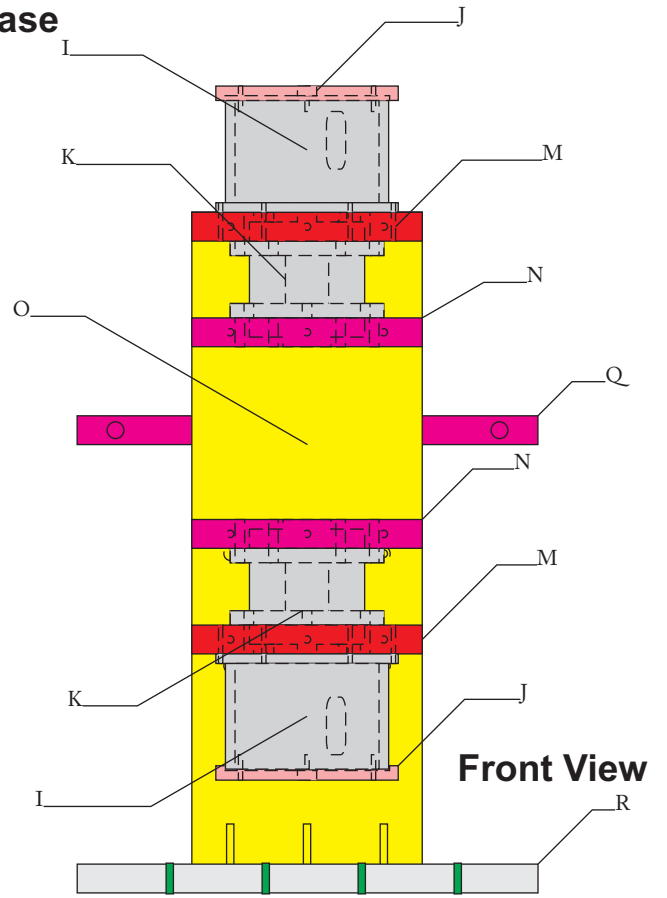

Front View

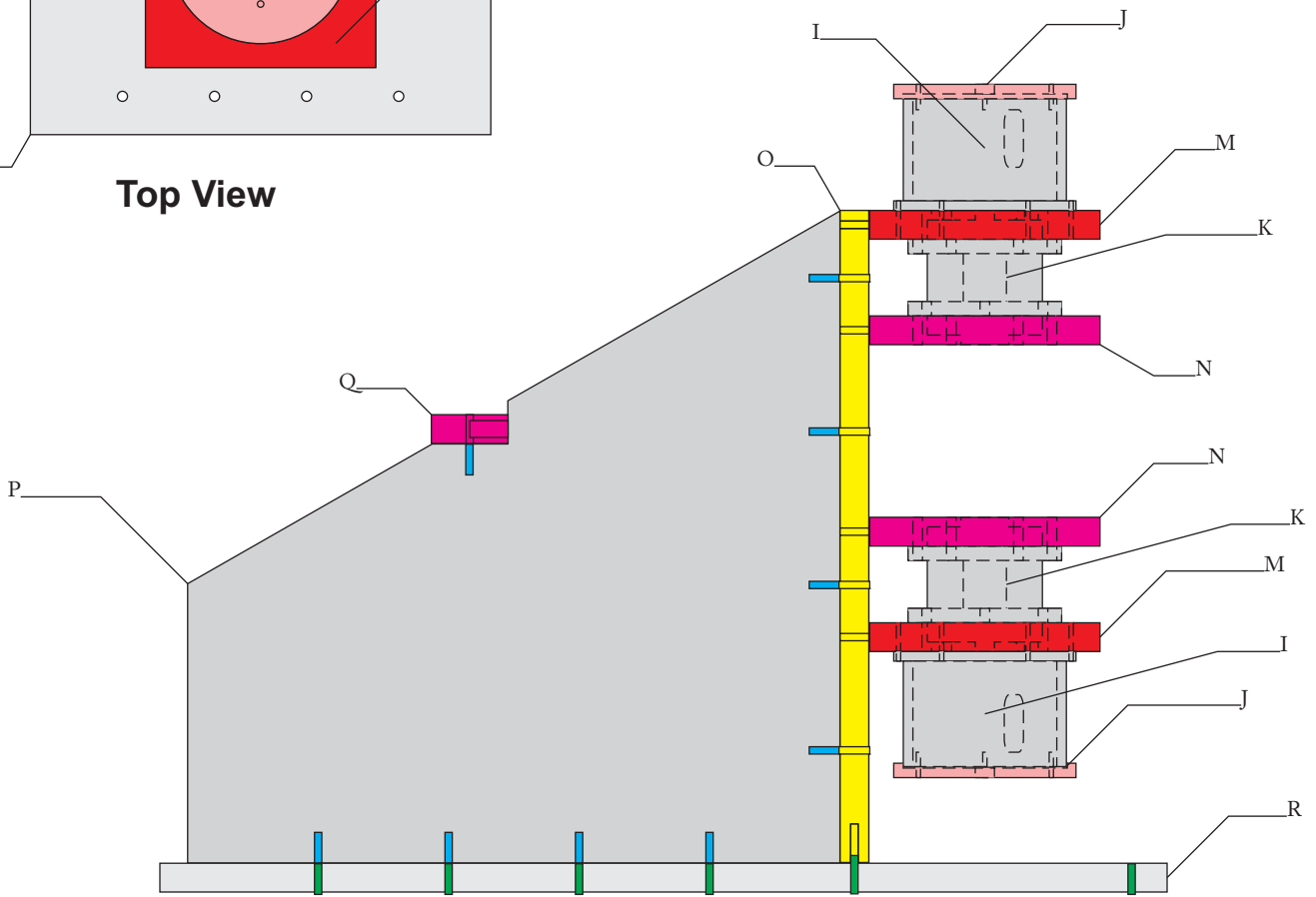

Side View

Handle Assembly

A

Side View

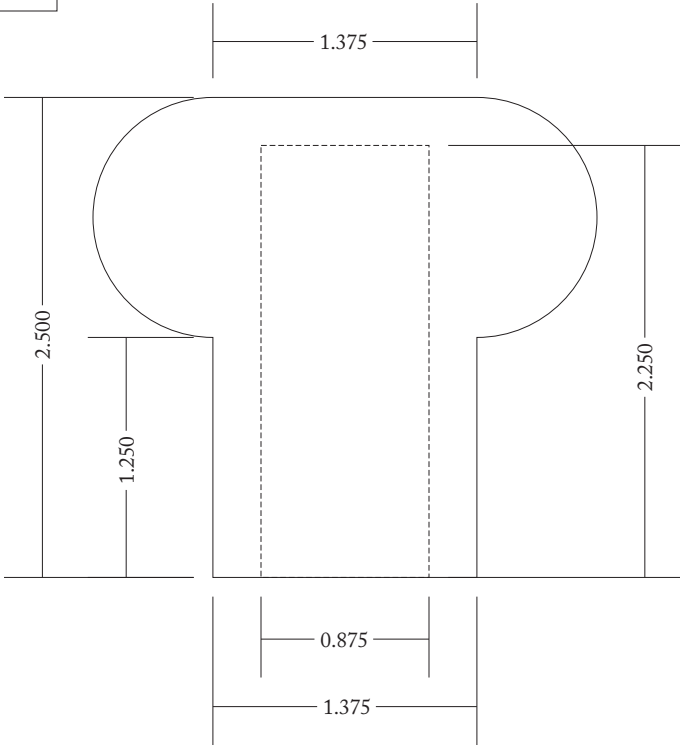

Top View

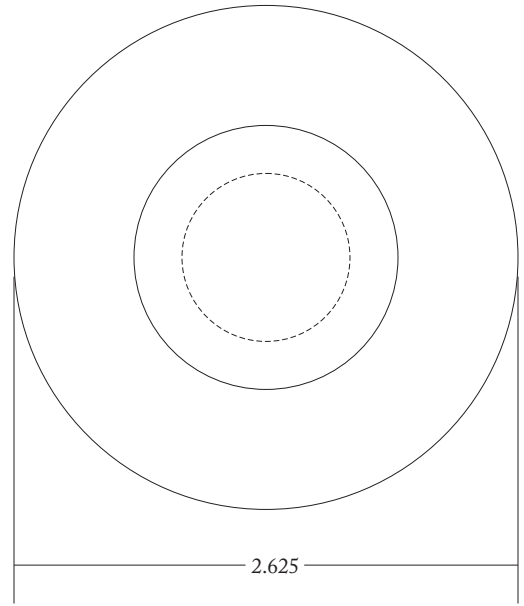

B

Side View

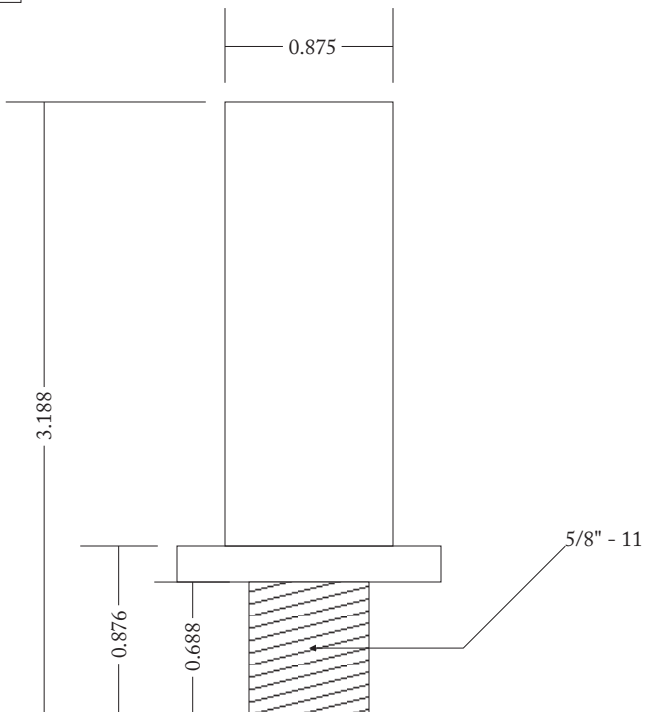

Top View

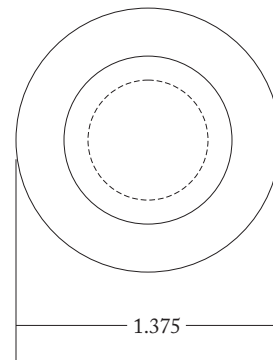

Handle Assembly Mounting Plate

C

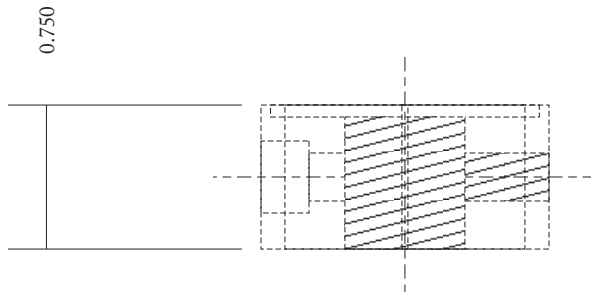
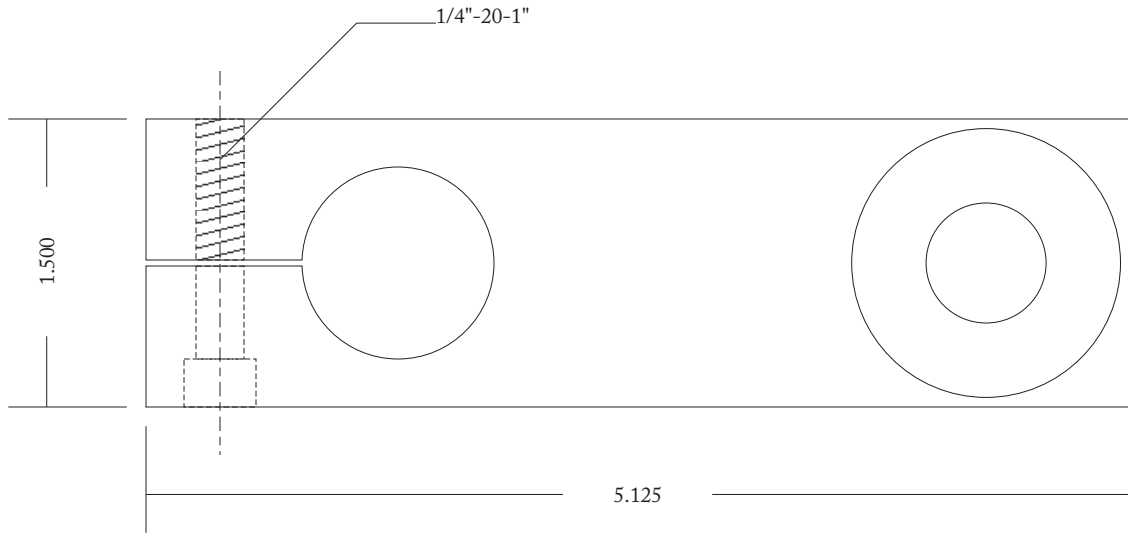
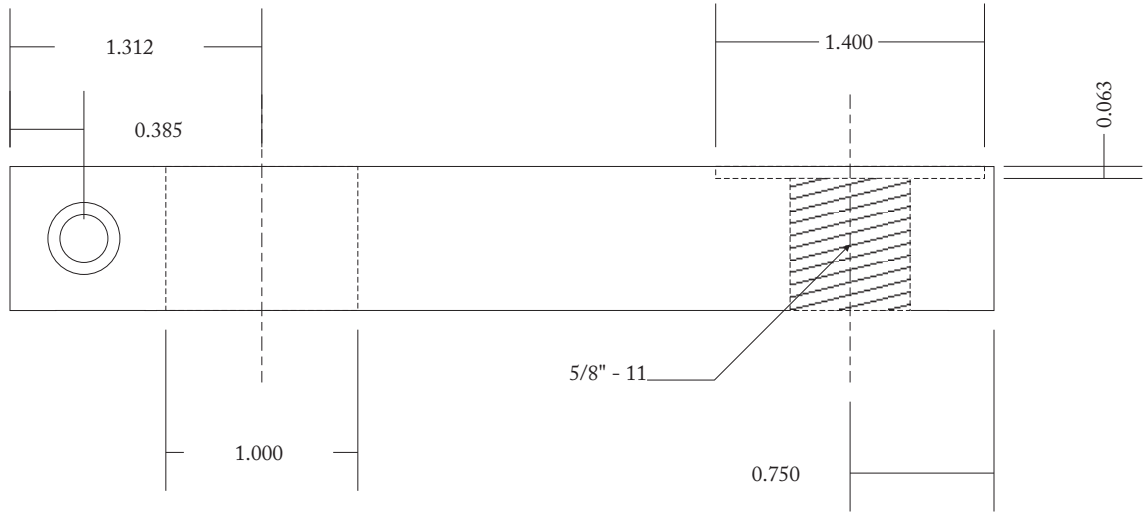

D

Handle Assembly Mounting Clamp

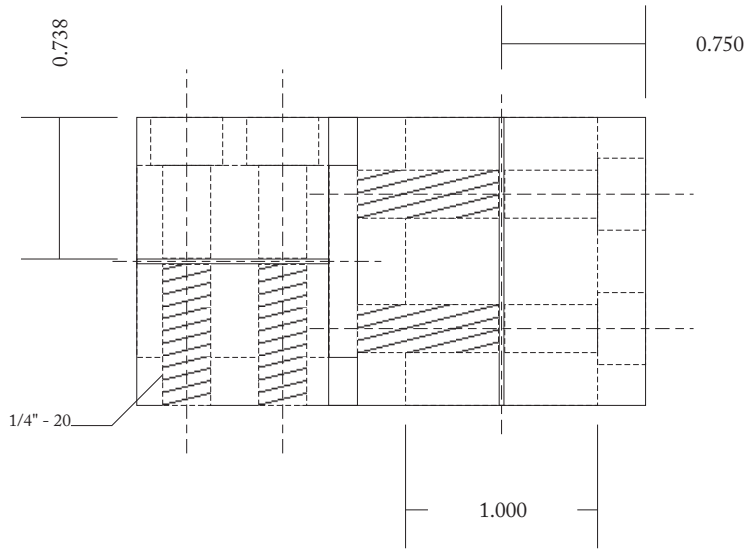

Side View

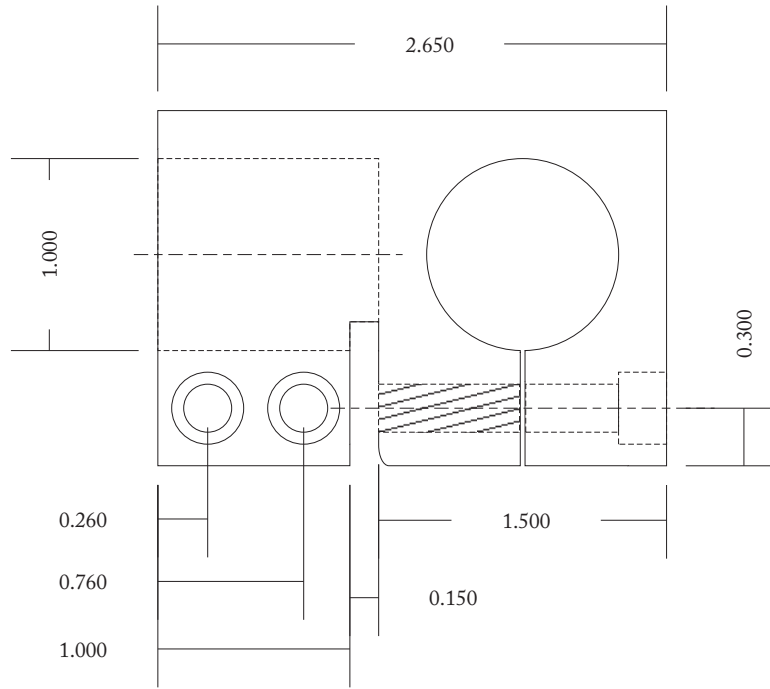

Top View

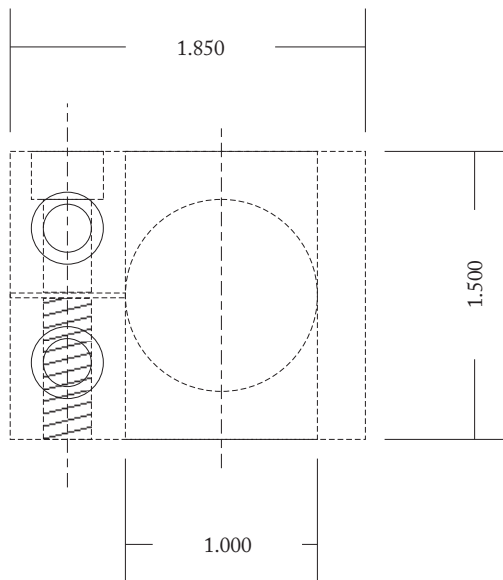

Front View

E

Elbow-Lower Arm Coupling

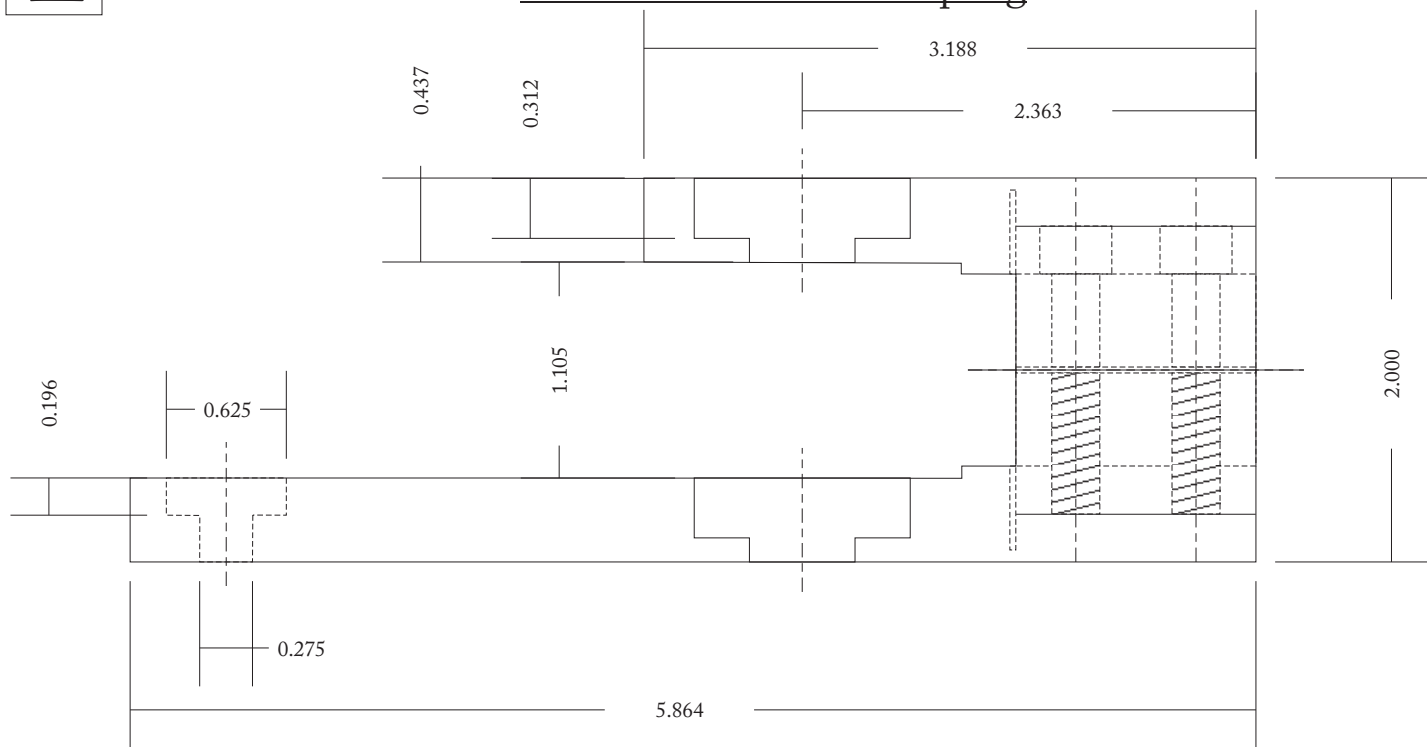

Side View

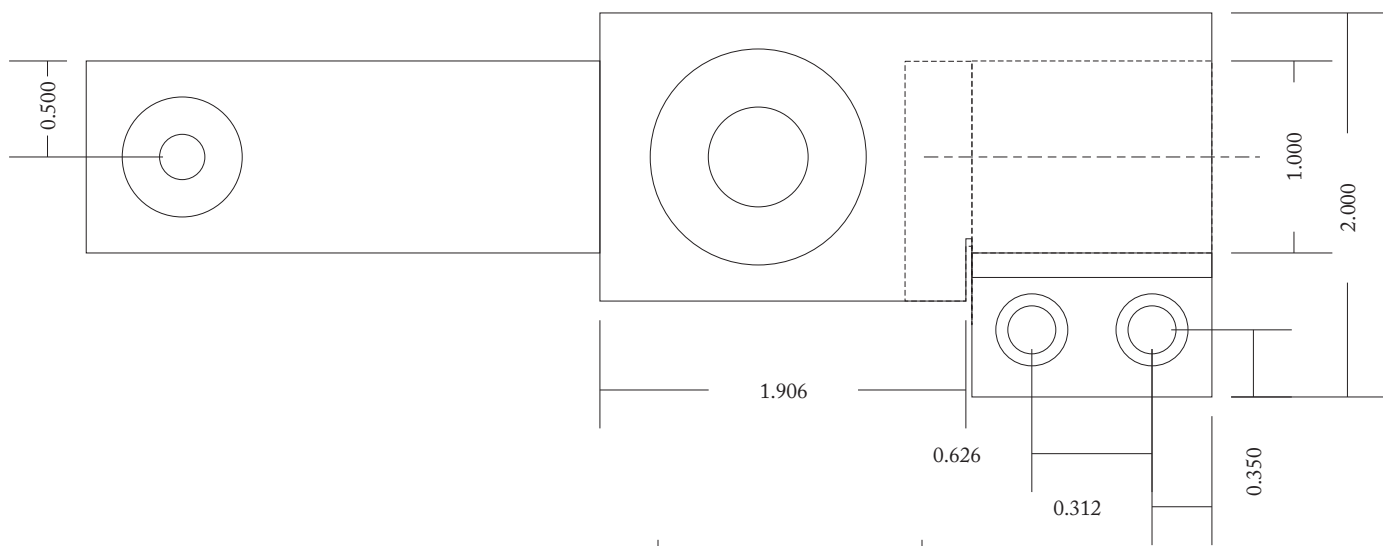

Top View

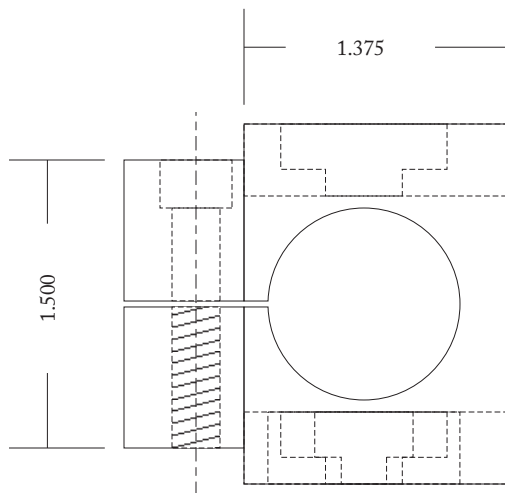

Front View

F

Elbow-Upper Arm Coupling #1

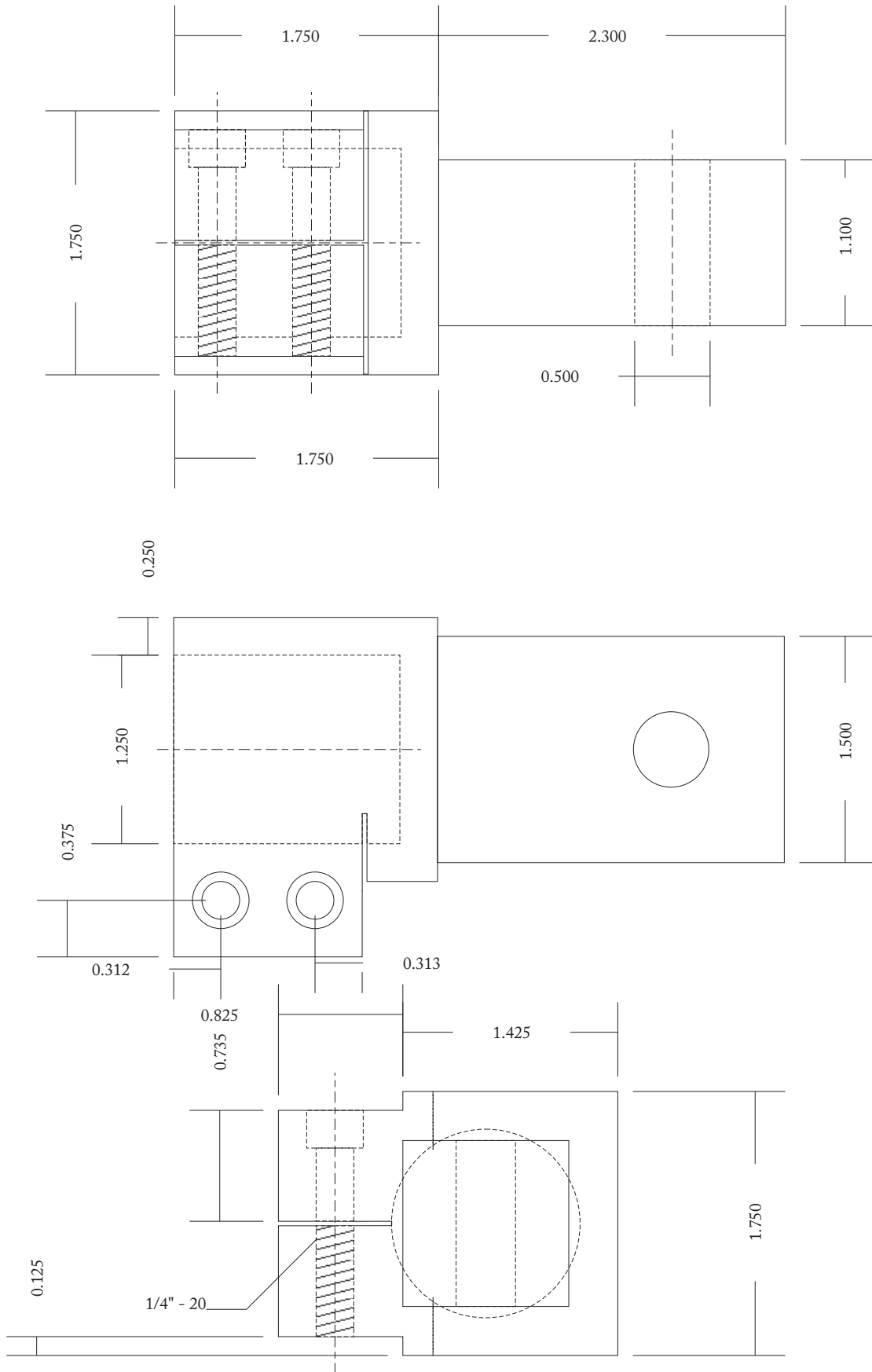

Side View

Top View

Front View

G

Elbow-Upper Arm Coupling #2

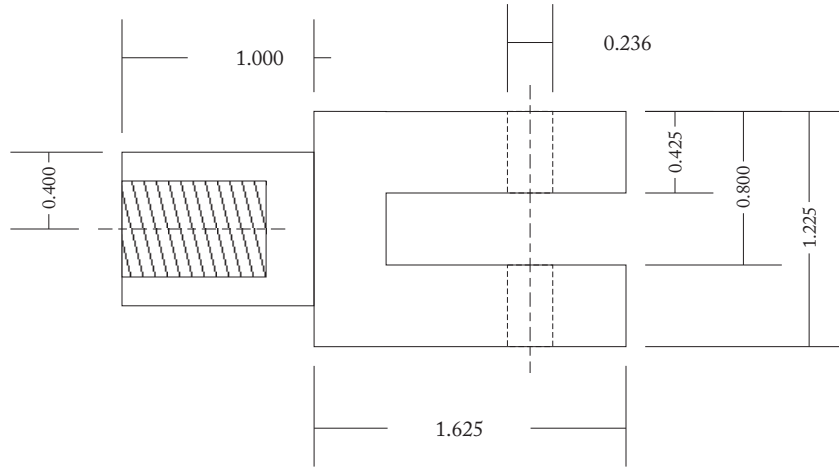

Side View

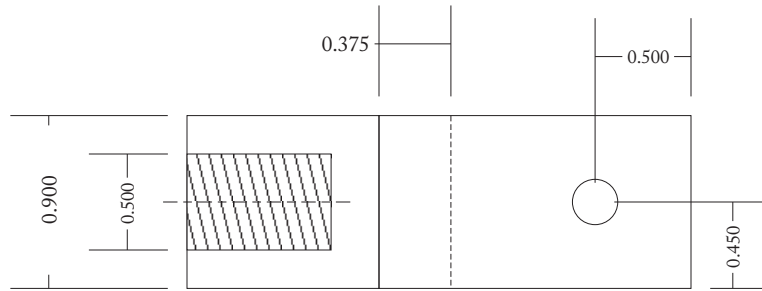

Top View

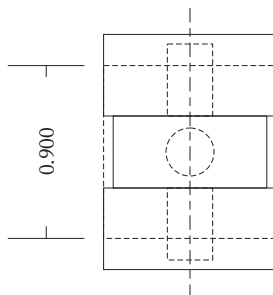

Front View



Shoulder-Elbow Coupling

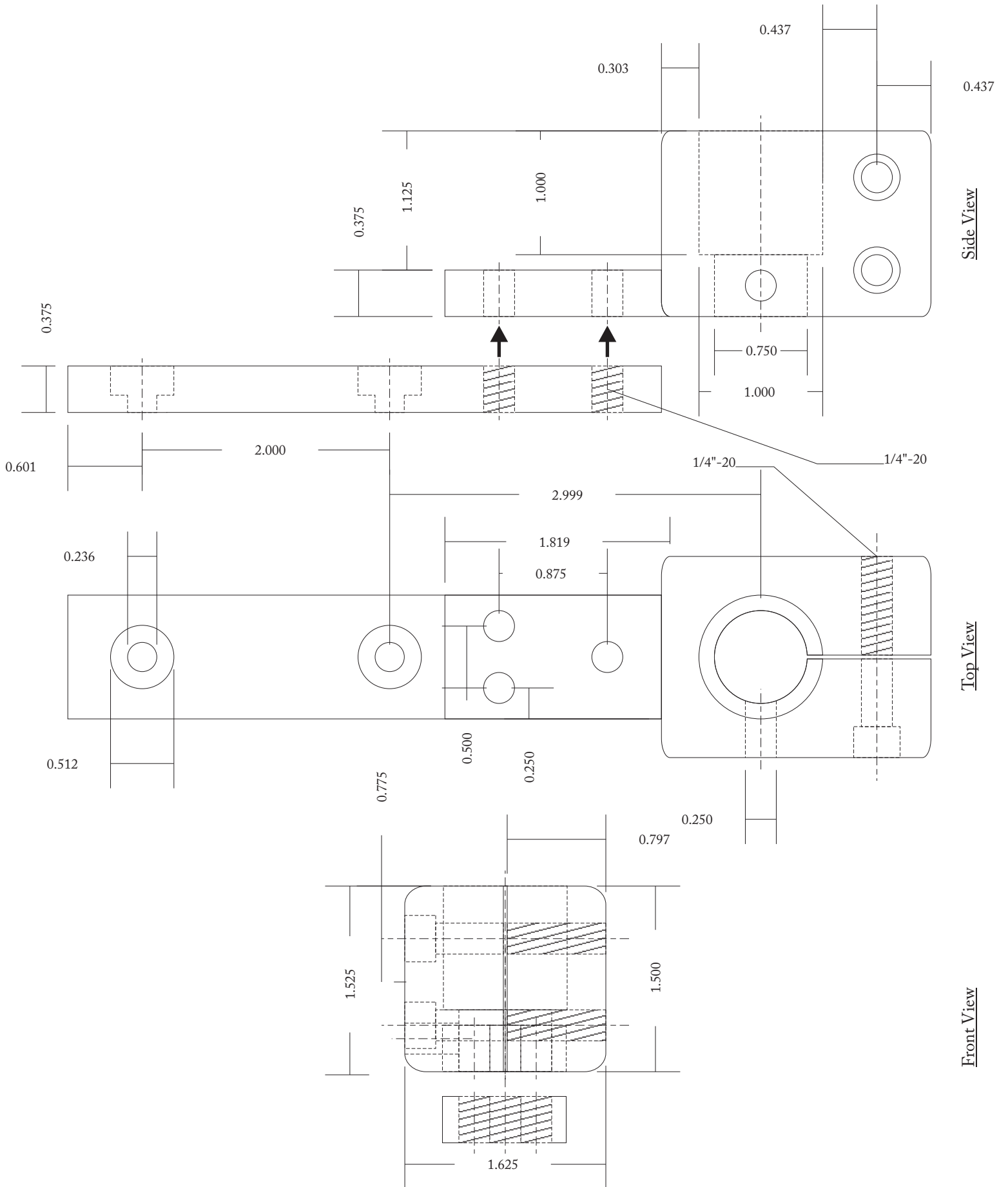

I

Shoulder-Upper-Arm Coupling

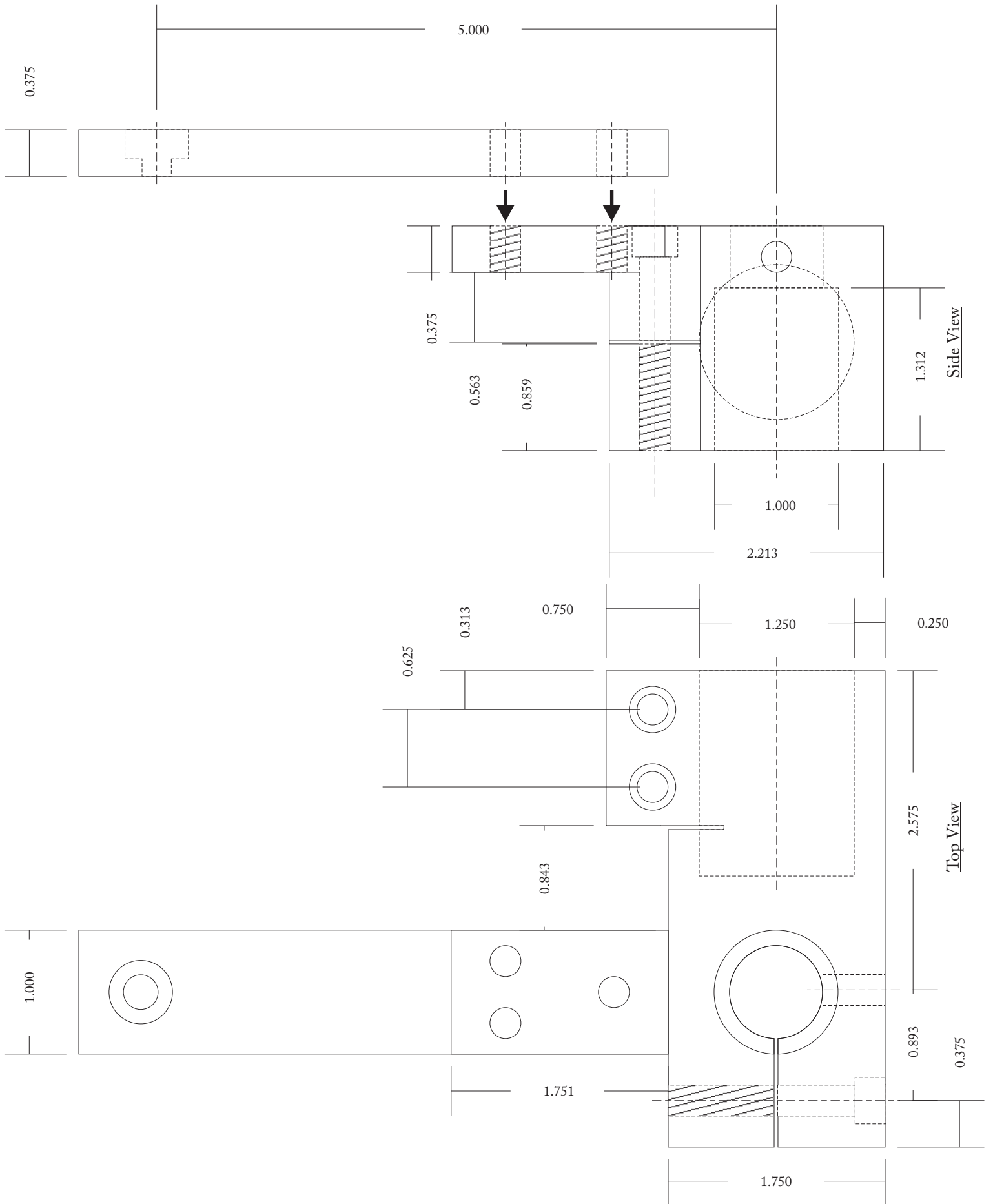

I

Hollow-Shaft Encoder Housing

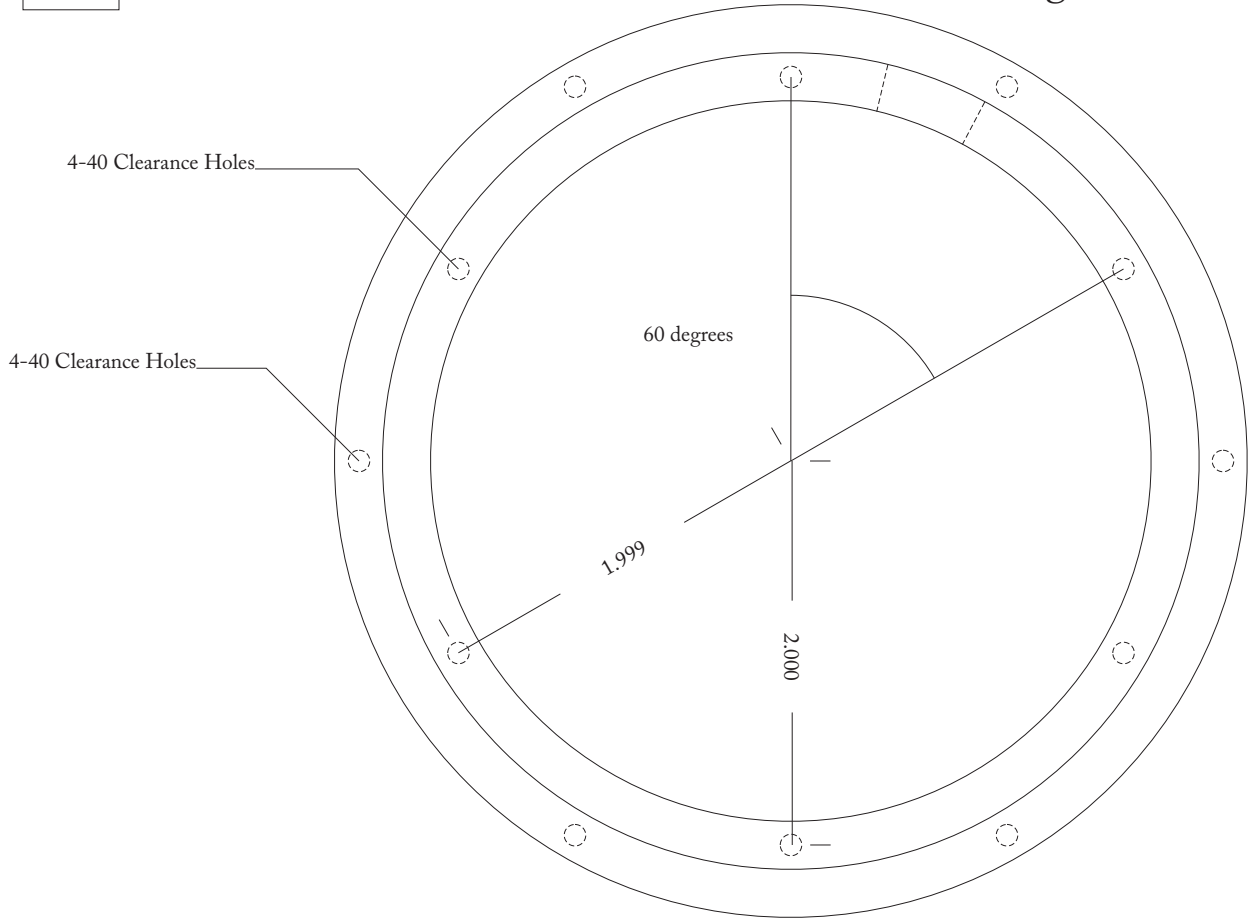

Side View

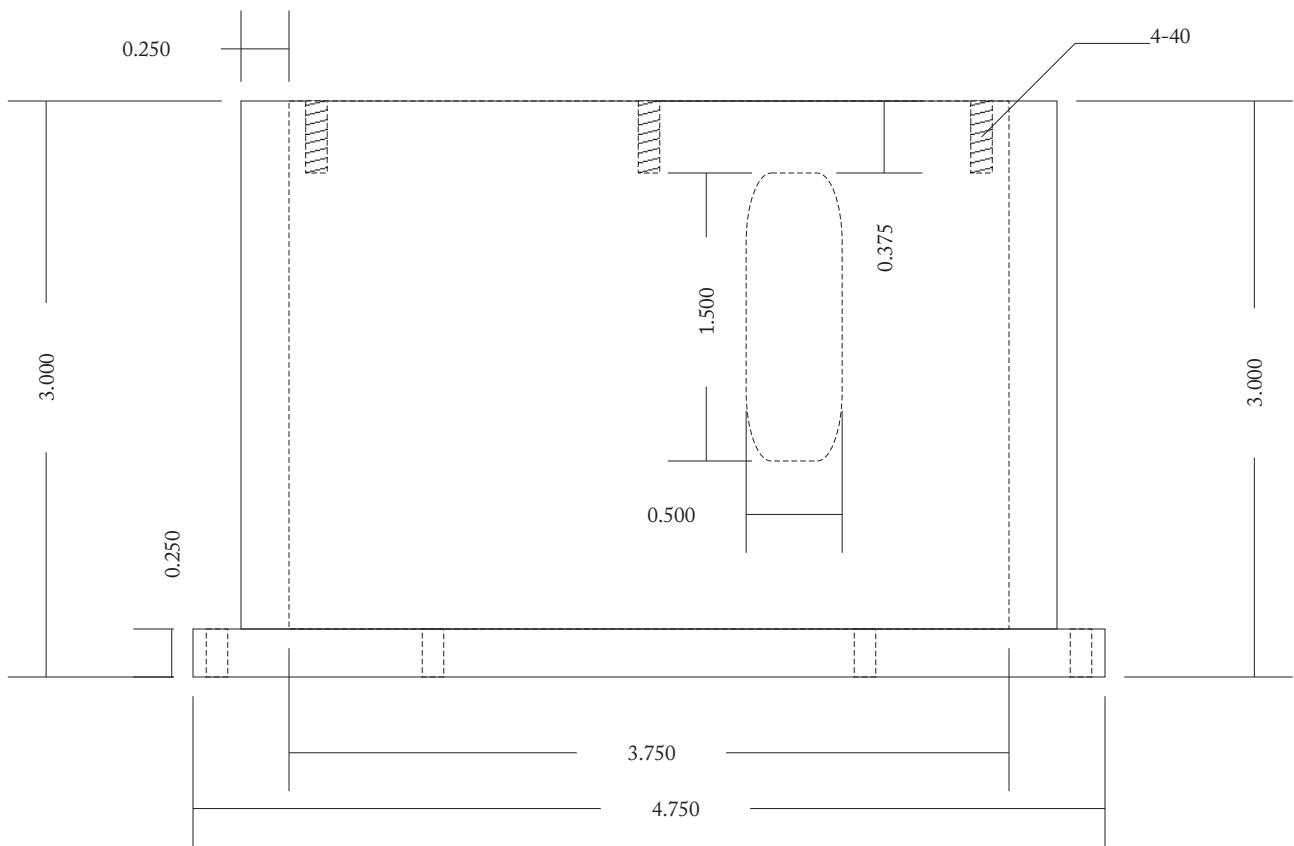

Top View

J

Hollow-Shaft Encoder Housing Lid

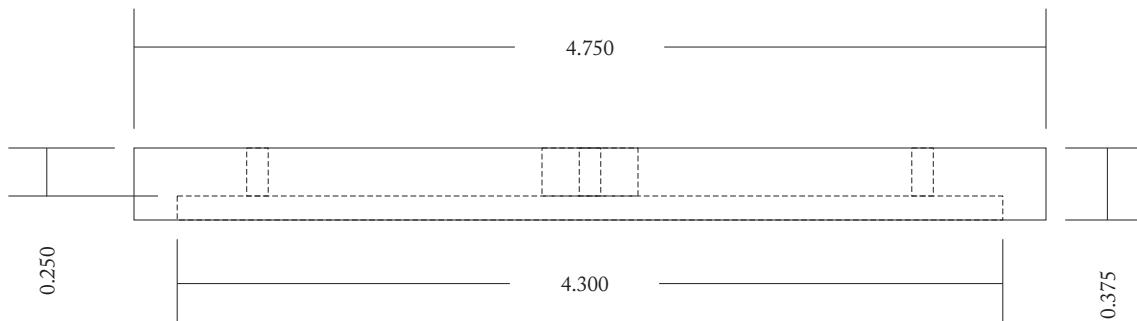
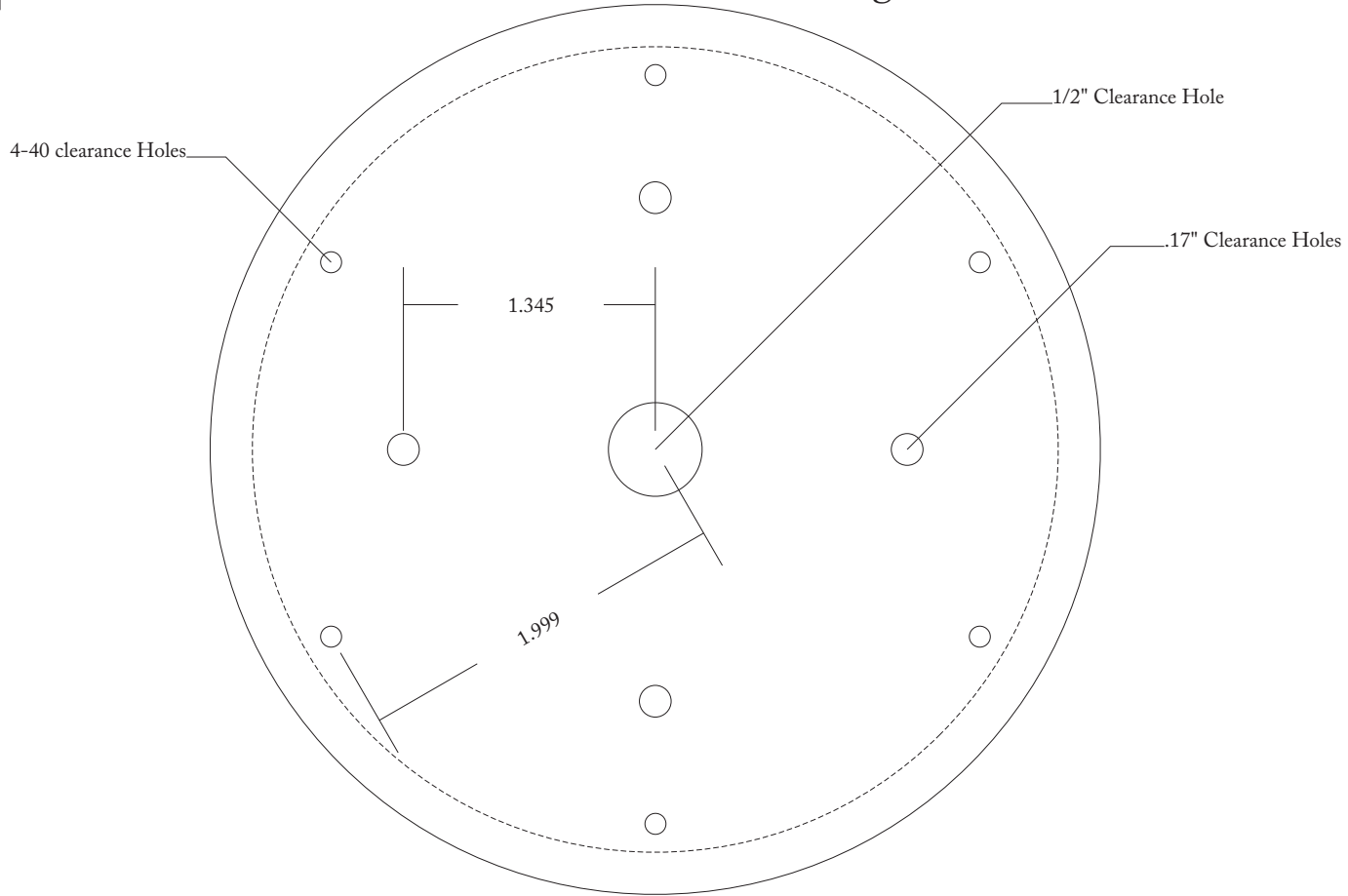

K

Shoulder Pivot Housing Assembly

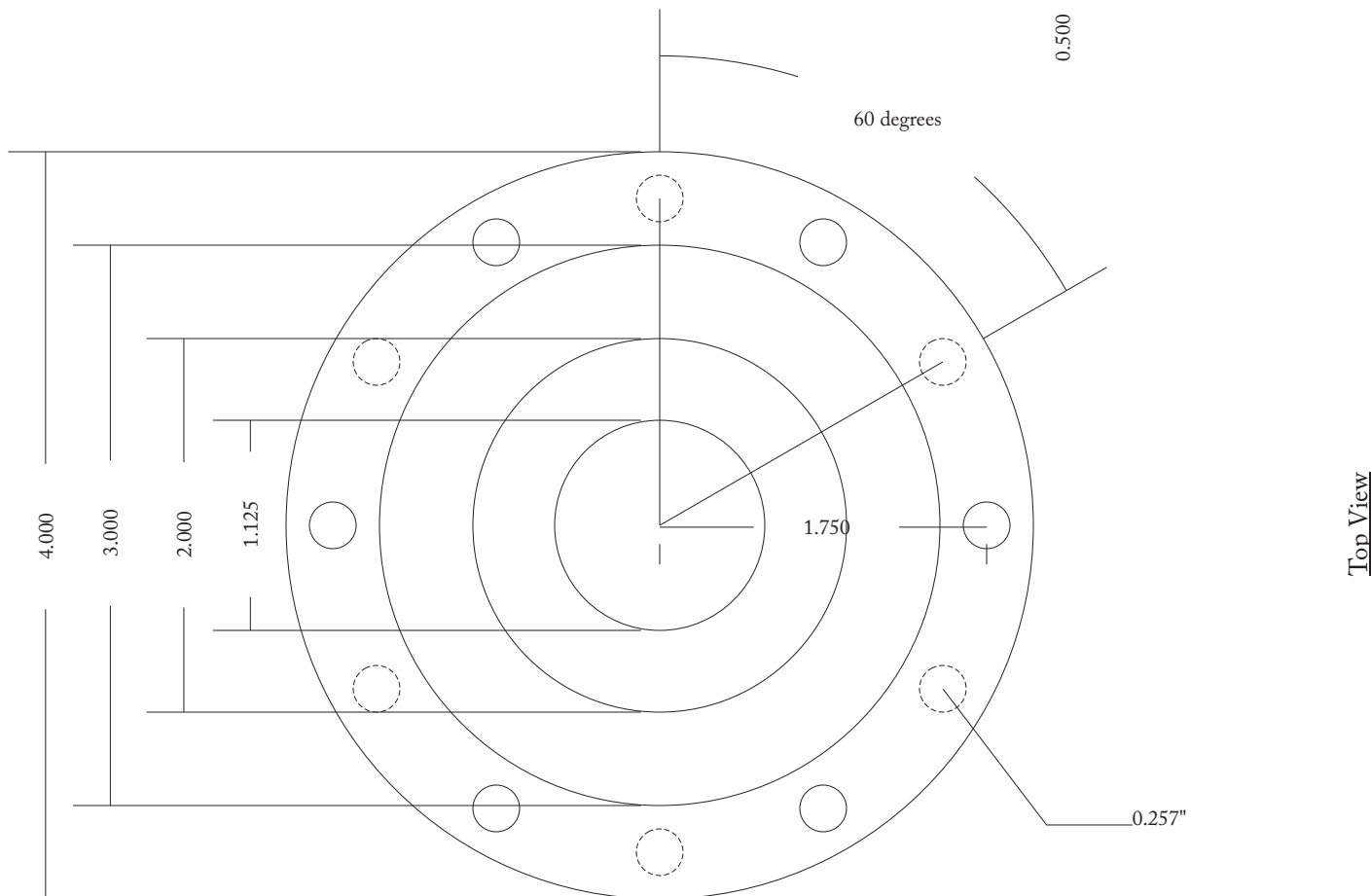
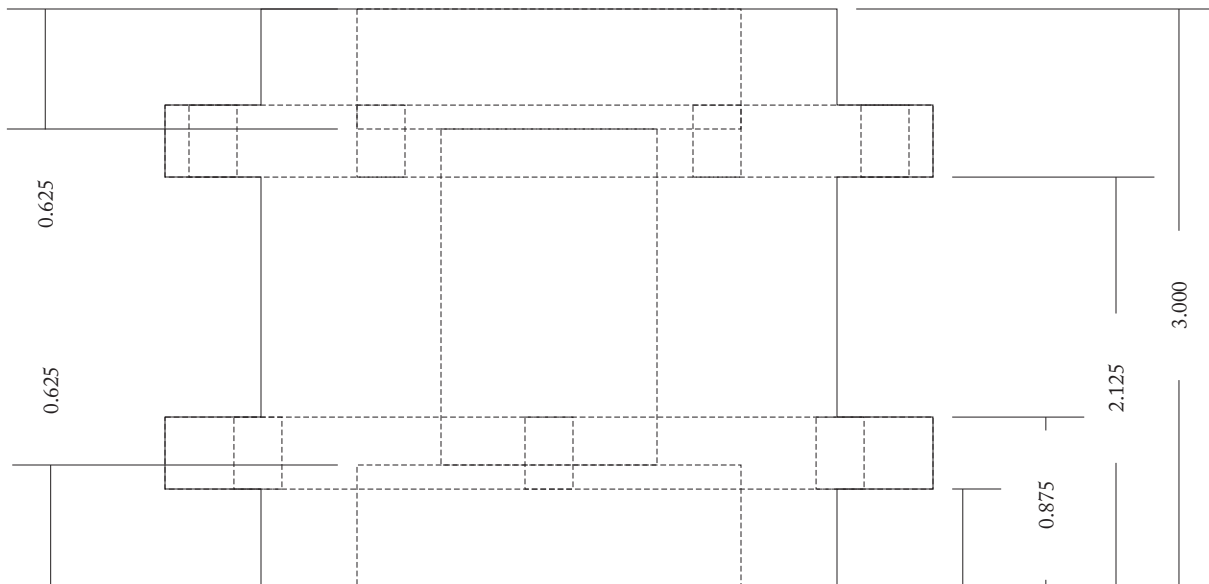

L

Shoulder Pivots & Shoulder Pivot Retaining Nuts

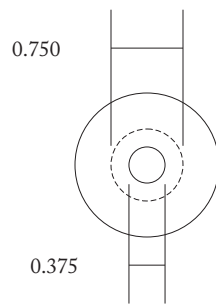
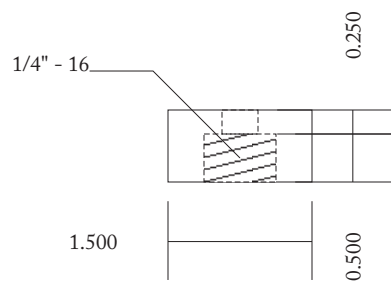
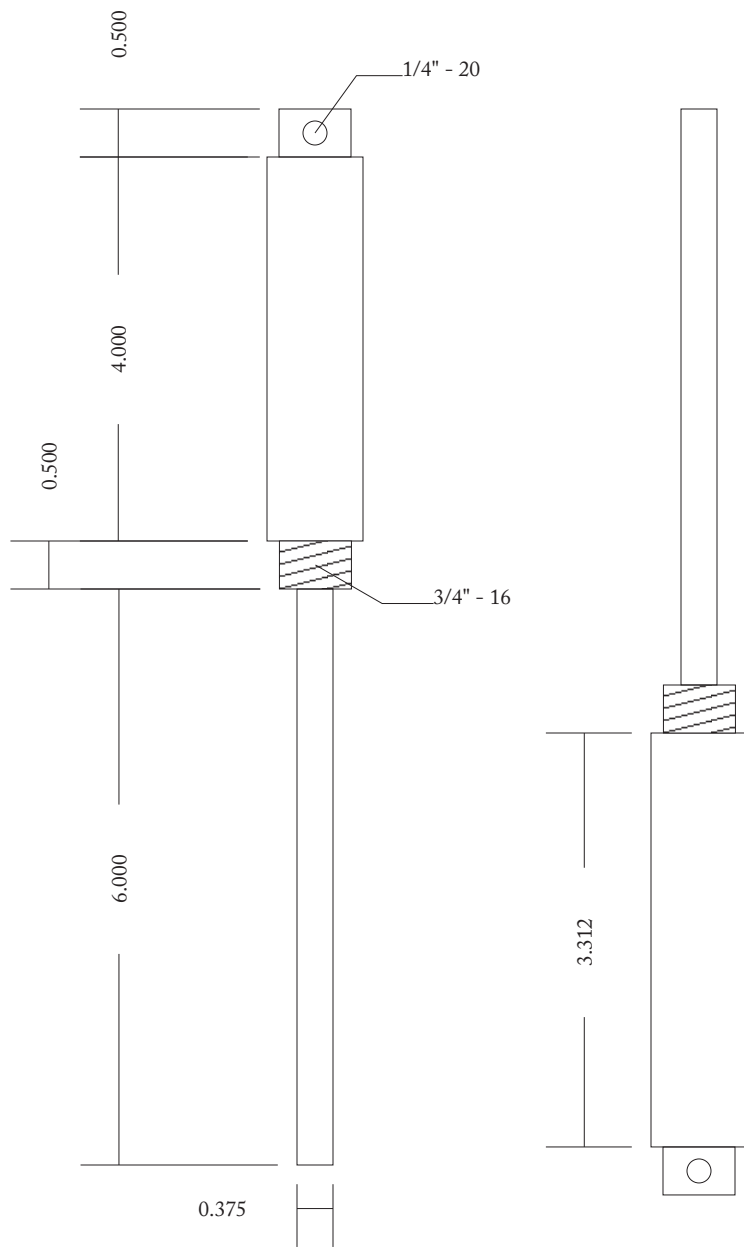



Outer Shoulder Pivot Housing Assembly Mounting Plate

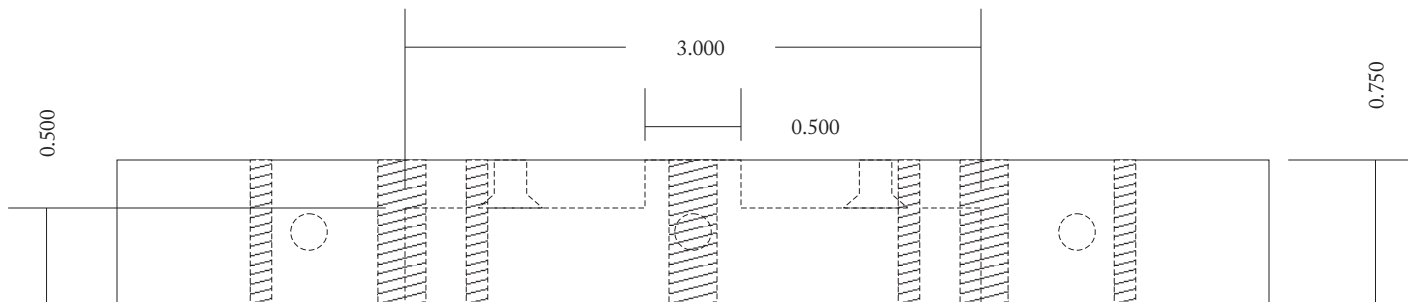
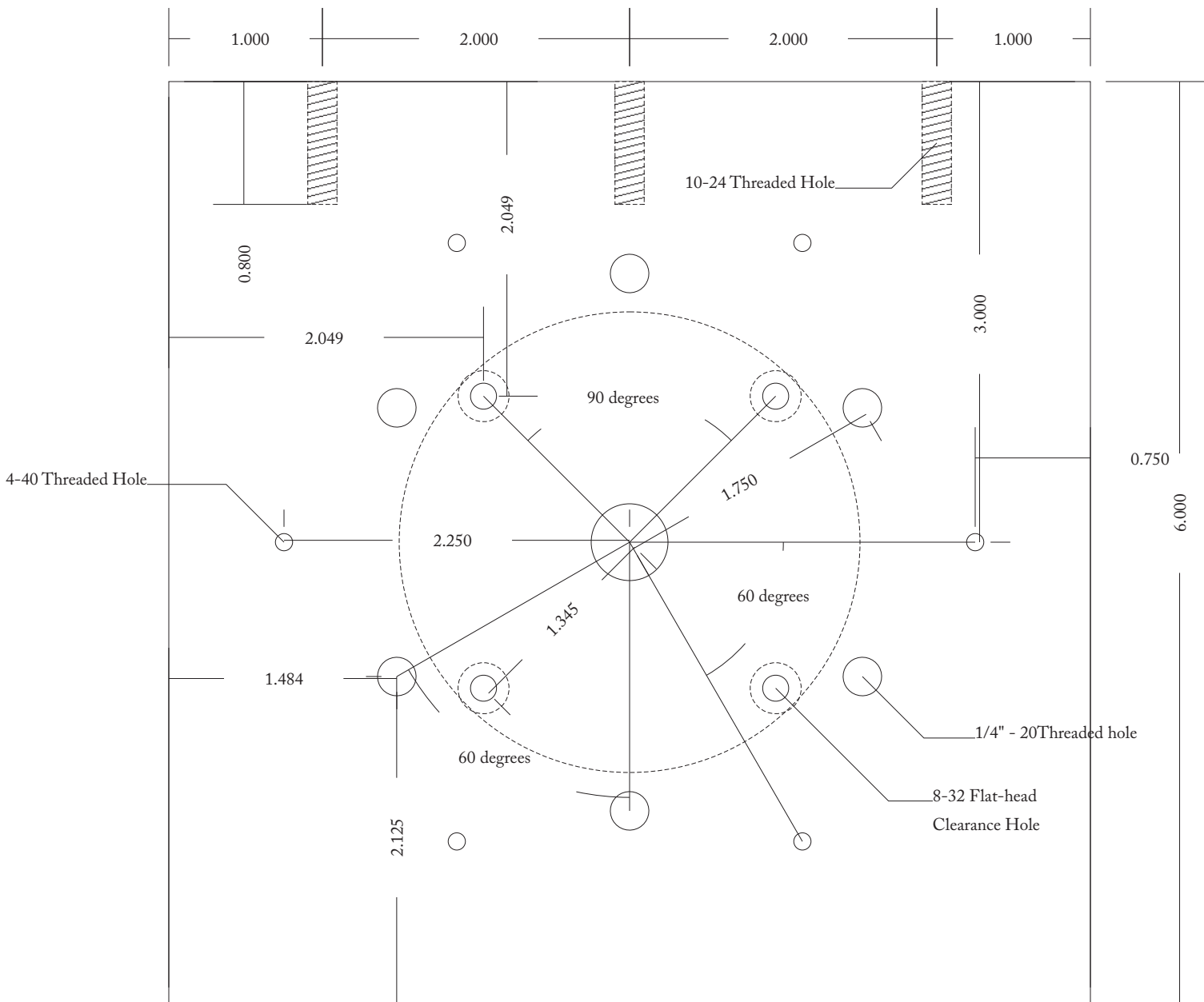



Inner Shoulder Pivot Housing Assembly Mounting Plate

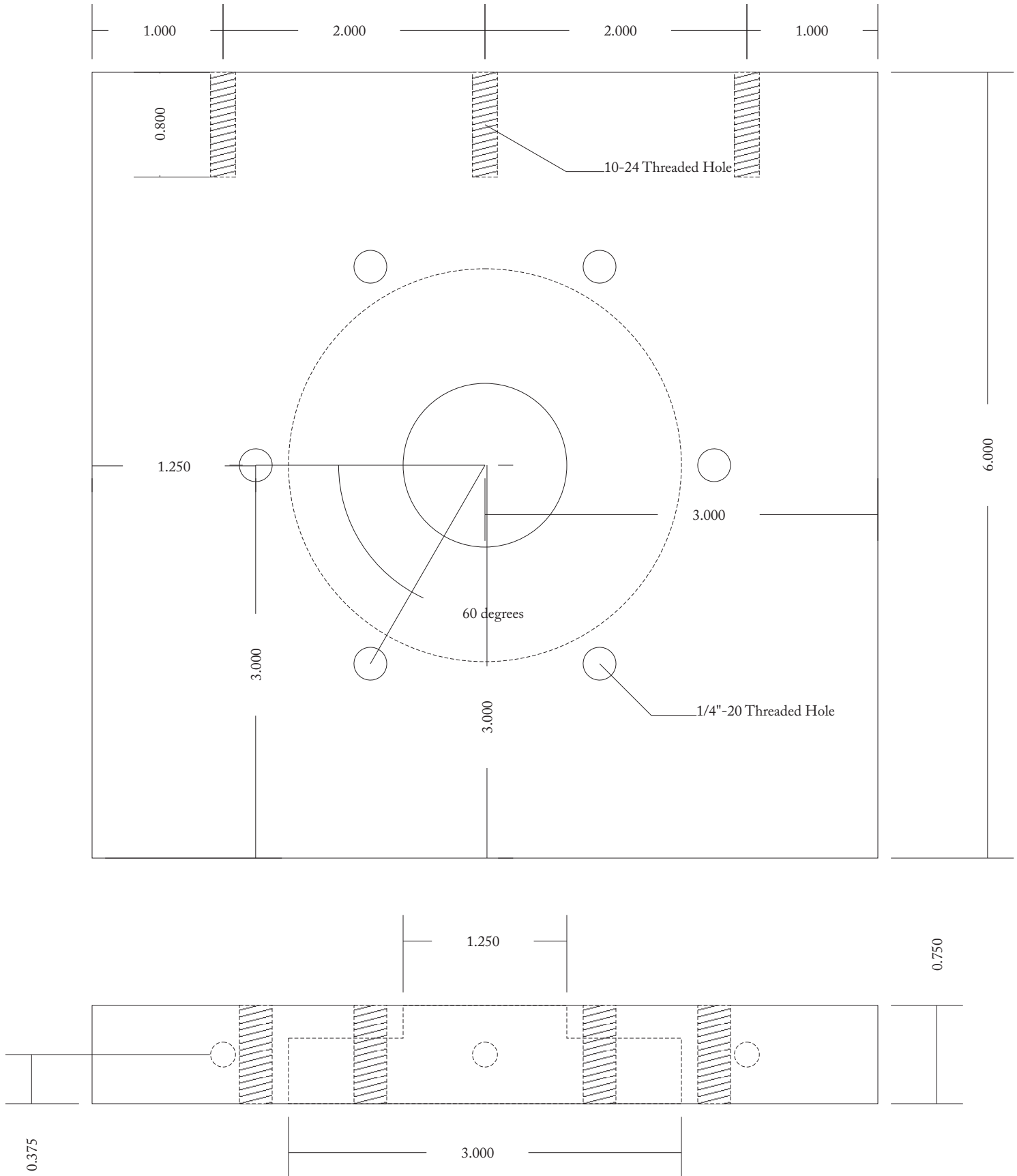



Shoulder Mounting Assembly Backplate

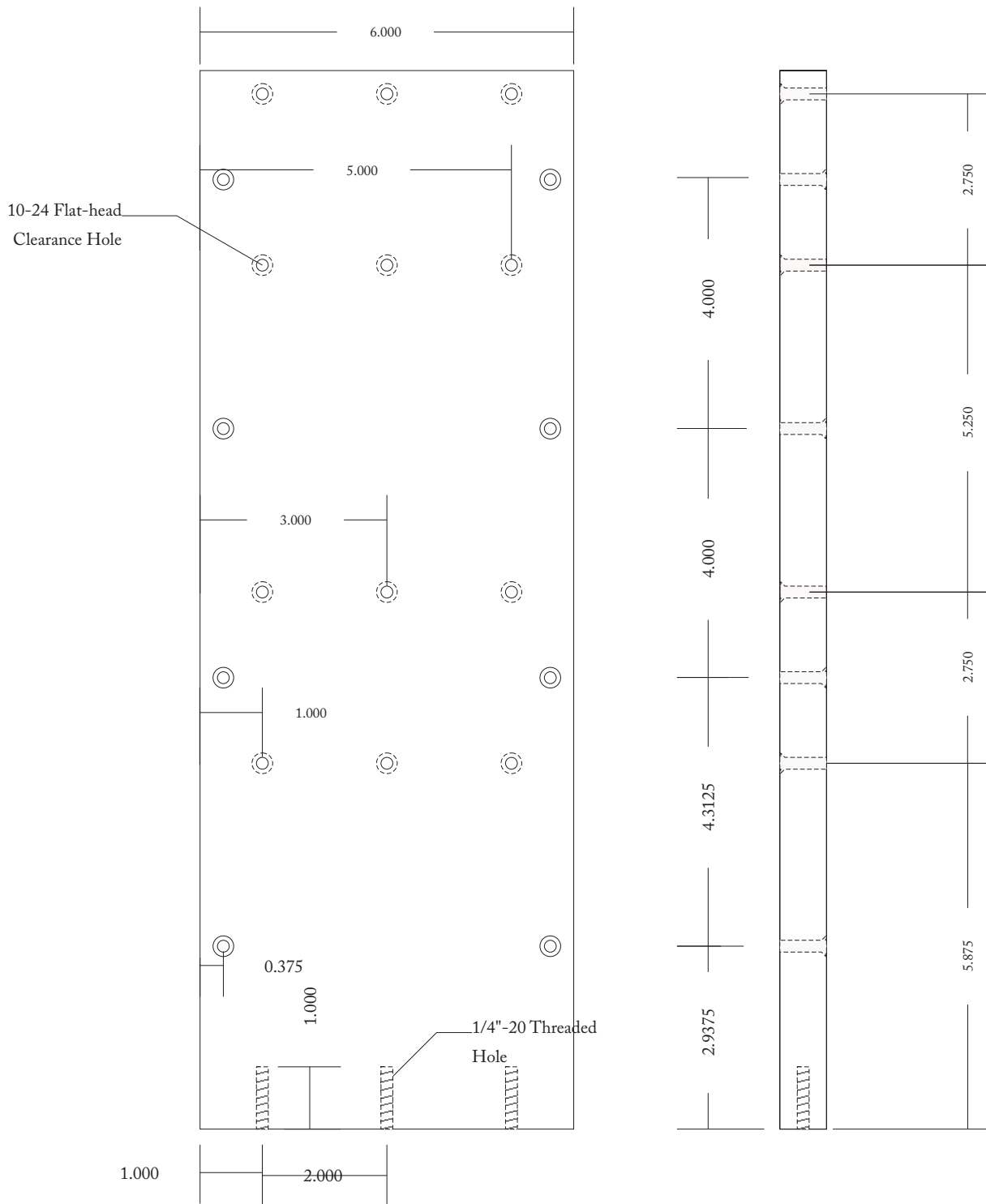

1.750
P

Shoulder Mounting Assembly Back Plate Support

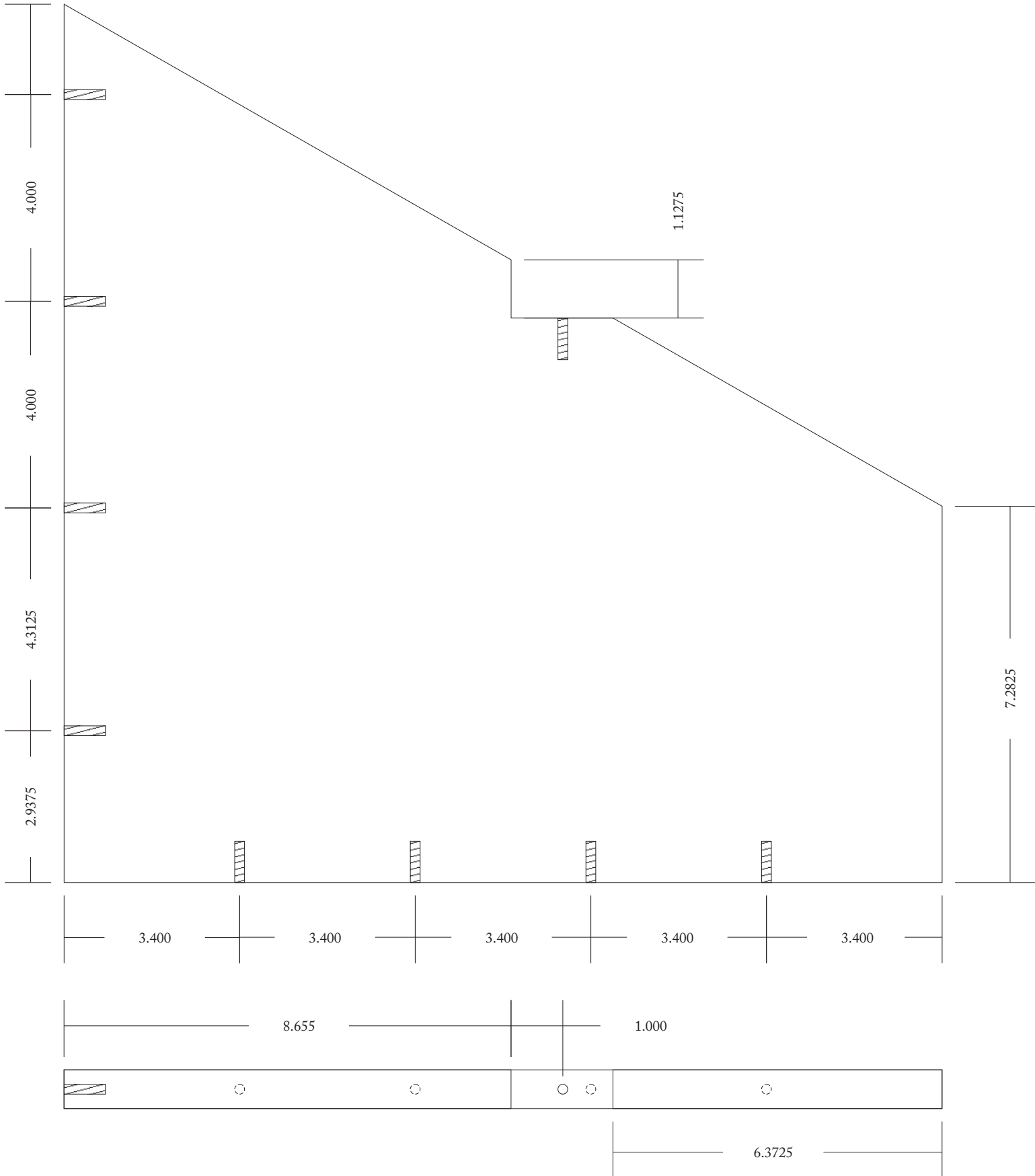



Air Cylinder Mounting Plate

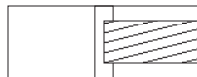
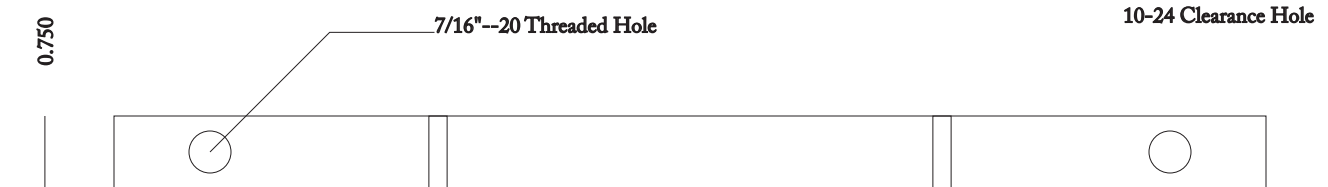
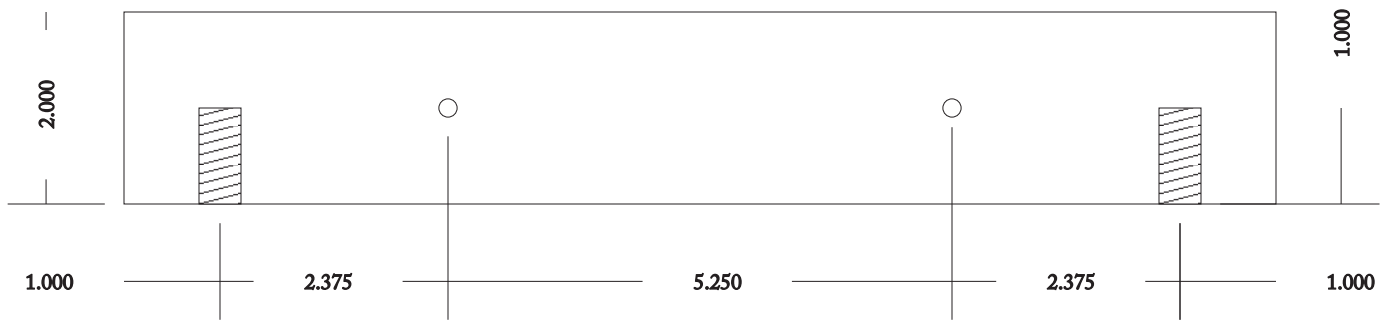

R

Base Plate

